

SIMATIC system power supply

SIMATIC S7-1200 G2 load power supply module PM 1207 120 W 120 - 240 V AC/DC

Equipment Manual

Overview

Safety instructions

1

Description, design of the
device, dimension drawing

2

Mounting/removal

3

Mounting position,
mounting clearances

4

Installation

5

Technical data

6

Safety, approvals, EMC

7

Ambient conditions

8

Applications

9

Environment

10

Service & Support

11




PM 1207 24 V/5 A
6EP3333-4SB00-3AX0

PM 1207 Ex 24 V/5 A
6EP3333-4SC00-3AX0

Legal information

Warning notice system

This manual contains notices you have to observe in order to ensure your personal safety, as well as to prevent damage to property. The notices referring to your personal safety are highlighted in the manual by a safety alert symbol, notices referring only to property damage have no safety alert symbol. These notices shown below are graded according to the degree of danger.

 DANGER
indicates that death or severe personal injury will result if proper precautions are not taken.
 WARNING
indicates that death or severe personal injury may result if proper precautions are not taken.
 CAUTION
indicates that minor personal injury can result if proper precautions are not taken.
NOTICE
indicates that property damage can result if proper precautions are not taken.


If more than one degree of danger is present, the warning notice representing the highest degree of danger will be used. A notice warning of injury to persons with a safety alert symbol may also include a warning relating to property damage.

Qualified Personnel

The product/system described in this documentation may be operated only by **personnel qualified** for the specific task in accordance with the relevant documentation, in particular its warning notices and safety instructions. Qualified personnel are those who, based on their training and experience, are capable of identifying risks and avoiding potential hazards when working with these products/systems.

Proper use of Siemens products

Note the following:

 WARNING
Siemens products may only be used for the applications described in the catalog and in the relevant technical documentation. If products and components from other manufacturers are used, these must be recommended or approved by Siemens. Proper transport, storage, installation, assembly, commissioning, operation and maintenance are required to ensure that the products operate safely and without any problems. The permissible ambient conditions must be complied with. The information in the relevant documentation must be observed.

Trademarks

All names identified by ® are registered trademarks of Siemens Aktiengesellschaft. The remaining trademarks in this publication may be trademarks whose use by third parties for their own purposes could violate the rights of the owner.

Disclaimer of Liability

We have reviewed the contents of this publication to ensure consistency with the hardware and software described. Since variance cannot be precluded entirely, we cannot guarantee full consistency. However, the information in this publication is reviewed regularly and any necessary corrections are included in subsequent editions.

Overview

Description



The load power supply module PM 1207 120 W 120 - 240 V AC/DC supplies input and output circuits (load circuits) as well as sensors and actuators of the SIMATIC S7-1200 G2.

The load power supply module has the following properties:

Technical properties

- Rated input voltage 1 AC 120 - 240 V AC, 50 - 60 Hz, 120 - 240 V DC
- 24 V DC rated output voltage
- 5 A rated output current
- 120 W output power
- Removable push-in terminals (below the front cap cover)
- Push-in connections facilitate fast wiring
- Diagnostic interface to visualize the operating state
- Digital documentation via ID Link
- Wall mounting

Ordering data

The following device options are available:

PM 1207 load current supply modules	
Type	Article number
Input 1 AC 120 - 240 V, 120 - 240 V DC Output 24 V DC/5 A	6EP3333-4SB00-3AX0

Load current supply modules PM 1207 Ex	
Type	Article number
Input 1 AC 120 - 240 V, 120 - 240 V DC Output 24 V DC/5 A	6EP3333-4SC00-3AX0


Table of contents

	Overview	3
1	Safety instructions	7
1.1	General safety instructions.....	7
1.2	Safety instructions for hazardous zones.....	8
2	Description, design of the device, dimension drawing	9
2.1	Device description	9
2.2	Connections and terminal designation	10
2.3	Status displays and signaling.....	11
2.4	Operating mode	12
2.5	Block diagram.....	13
2.6	Dimensions and weight	14
3	Mounting/removal	15
4	Mounting position, mounting clearances	17
4.1	Other mounting positions	18
5	Installation	21
5.1	Line-side connection	21
5.2	Output-side connection	23
5.3	Connecting the diagnostic interface	24
6	Technical data	25
6.1	Input	25
6.2	Output	27
6.3	Efficiency.....	29
6.4	Closed-loop control.....	30
6.5	Protection and monitoring	30
6.6	MTBF.....	30
6.7	Mechanical system	31
6.8	Accessories	31
6.9	Dimension drawing.....	32

7	Safety, approvals, EMC	33
7.1	Safety.....	33
7.2	Test voltage.....	34
7.3	Approvals	35
7.4	EMC	36
8	Ambient conditions	37
9	Applications	39
9.1	Parallel connection to increase the power rating	39
9.2	Series connection for increased voltage	41
9.3	Overload protection in the 24 V output circuit.....	42
9.4	Protection against short-time voltage dips.....	43
9.5	Protecting against longer power failures	44
10	Environment	47
11	Service & Support	49

Safety instructions

1.1 General safety instructions

 WARNING
Correct handling of the devices
When operating electrical devices, it is inevitable that certain components will carry dangerous voltages.
Therefore, failure to handle the units properly can result in death or serious physical injury as well as extensive property damage.
Only appropriately qualified personnel may work on or in the vicinity of this equipment.
Perfect, safe, and reliable operation of this equipment is dependent on proper transportation, storage, installation and mounting.
Before installation or maintenance work can begin, the system's main switch must be switched off and measures taken to prevent it being switched on again.
If this instruction is not observed, touching live parts can result in death or serious injury.

1.2 Safety instructions for hazardous zones

It is only permissible that the devices listed below are used in hazardous zones.

Type	Article number
Power supply module PM 1207 Ex 24 V/5 A	6EP3333-4SC00-3AX0

The device complies with ATEX directive 2014/34/EU: EN IEC 60079-0; EN 60079-7; EN IEC 60079-15

UKSI 2016: 1107: BS EN IEC 60079-0; BS EN 60079-7; BS EN IEC 60079-15

CCC: GB/T3836.1-2021; GB/T3836.3-2021; GB/T3836.8-2021

UL: Suitable for Ex applications in CLASS I, DIVISION 2, GROUPS A, B, C and D - or in non-hazardous zones only; max. 2000 m

IECEX/ATEX: II 3G Ex ec IIC (T4...T3) Gc

-25 °C ≤ T_{amb} ≤ 55 °C: T4

-25 °C ≤ T_{amb} ≤ 70 °C: T3

 **WARNING**

EXPLOSION HAZARD – DO NOT CONNECT OR DISCONNECT EQUIPMENT UNLESS POWER HAS BEEN SWITCHED OFF OR THE AREA IS KNOWN TO BE NON-HAZARDOUS

 **WARNING**

EXPLOSION HAZARD – SUBSTITUTION OF COMPONENTS MAY IMPAIR SUITABILITY FOR CLASS I, DIVISION 2

 **WARNING**

It is only permissible to use the device in an area with a minimum pollution degree of 2 according to IEC 60664-1.

The maximum ambient air temperature inside the distribution box must be determined at a distance of 25 mm from the device.

When installing the device in a hazardous zone, this must be installed in a distribution box with degree of protection IP54 or higher. This distribution box must comply with the requirements of IEC/EN 60079-0/GB/T3836.1-2021 and must require a tool for opening.

Description, design of the device, dimension drawing

2

2.1 Device description

The PM 1207 power module is a primary-clocked power supply for connection to a 1-phase AC line supply or DC supply. An electronically controlled 24 V DC voltage is available at the output of the device. The output of the device is isolated, no-load proof and short-circuit proof. The LED display indicates the operating status. The operating state of the device can be processed via the diagnostic interface.

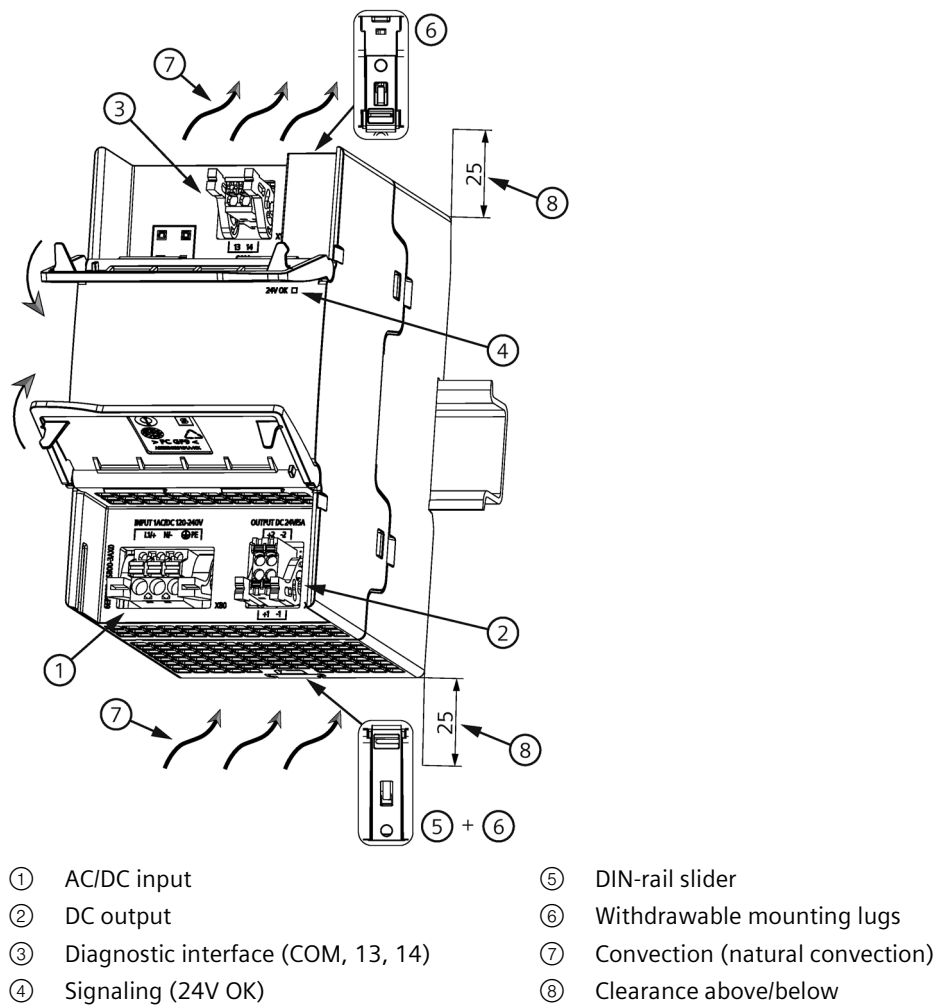


Figure 2-1 Design

2.2 Connections and terminal designation

The line input terminals ① can be used to establish the connection to the supply voltage. The output terminals ② are used to connect to the loads to be supplied (see also Chapter Installation (Page 21)).

The operating state of the device can be processed via the diagnostic interface ③ (function and contact rating, see Chapter Status displays and signaling (Page 11)).

The plug-in-terminals also have a color coding. The first color is the color of the connector release (release lever) and the second color is the color for the actuator (pusher) of the push-in terminal.

Connections and terminal designations	
① Line input L1/+, N/-, PE	One push-in terminal each (3-pole terminal block) Color coding orange/orange
② Output + and -	Two push-in terminals each (4-pole terminal block) Color coding black/gray
③ Diagnostic interface 13, 14	One push-in terminal each (2-pole terminal block) Color coding black/gray


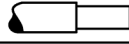


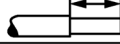
	①	②	③
	0,6 x 3,5	0,4 x 2,5	0,4 x 2,5
	1 x 0,2 - 2,5 mm ²	1 x 0,14 - 1,5 mm ²	1 x 0,14 - 1,5 mm ²
	1 x 0,2 - 2,5 mm ²	1 x 0,14 - 1,5 mm ²	1 x 0,14 - 1,5 mm ²
	1 x 0,25 - 2,5 mm ²	1 x 0,14 - 1,5 mm ²	1 x 0,25 - 1 mm ²
AWG	26 - 12	30 - 16	26 - 16
	10 mm	10 mm	8 mm

Figure 2-2 Terminal data

2.3 Status displays and signaling

	PM 1207 24 V/5 A 6EP3333-4SB00-3AX0	PM 1207 Ex 24 V/5 A 6EP3333-4SC00-3AX0
Operating display	Multi-color LED display at the front of the device indicates the operating state of the device: green for 24 V OK.	
Diagnostic interface COM (13, 14)	Relay contact (NO contact, isolated (SELV (ES1) must be complied with), contact rating 30 V DC/0.1 A) CAUTION: It is not permissible that the diagnostic interface is connected on the primary side! It is only used for communications!	

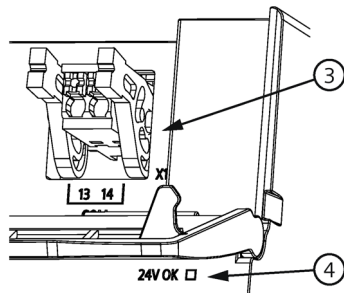


Figure 2-3 Operating display and diagnostic interface

Signaling, diagnostic interface	PM 1207 24 V/5 A 6EP3333-4SB00-3AX0	PM 1207 Ex 24 V/5 A 6EP3333-4SC00-3AX0
LED "24V OK" ④:	<ul style="list-style-type: none"> green: Output voltage OK yellow: Output voltage not OK (18.5 - 20.4 V) off: Output voltage not OK (< 18.5 V) 	
Diagnostic interface COM (13, 14) ③:	Only for communications! More detailed information is provided in document diagnostic interface (https://support.industry.siemens.com/cs/ww/en/view/109986608).	

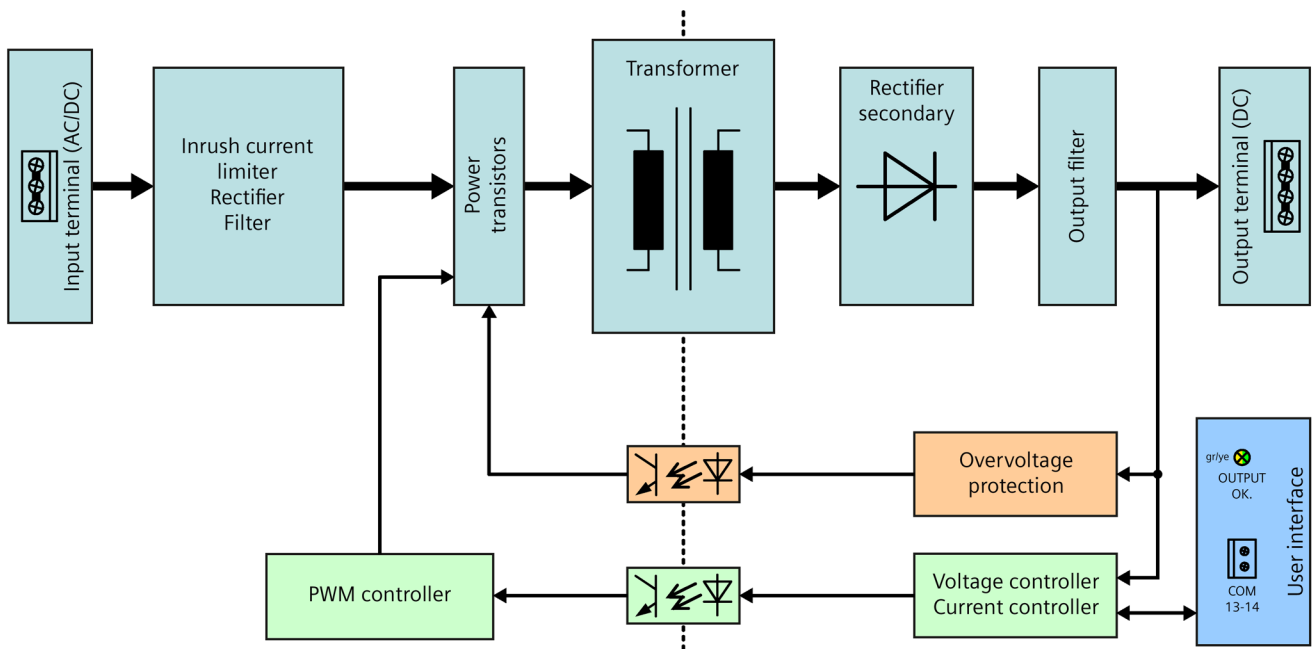
2.4 Operating mode

	PM 1207 24 V/5 A 6EP3333-4SB00-3AX0	PM 1207 Ex 24 V/5 A 6EP3333-4SC00-3AX0
COM ③:	Internal device parameters are transferred via the diagnostic interface COM (13, 14) CAUTION: It is not permissible that the diagnostic interface is connected on the primary side! It is only used for communications! Contact rating: 30 V DC/0.1 A	

Additional information can be found in the documents:

- Diagnostic interface (<https://support.industry.siemens.com/cs/ww/en/view/109986608>)
- Faceplates and communication blocks
(<https://support.industry.siemens.com/cs/ww/en/view/109986606>)

2.5 Block diagram



2.6 Dimensions and weight

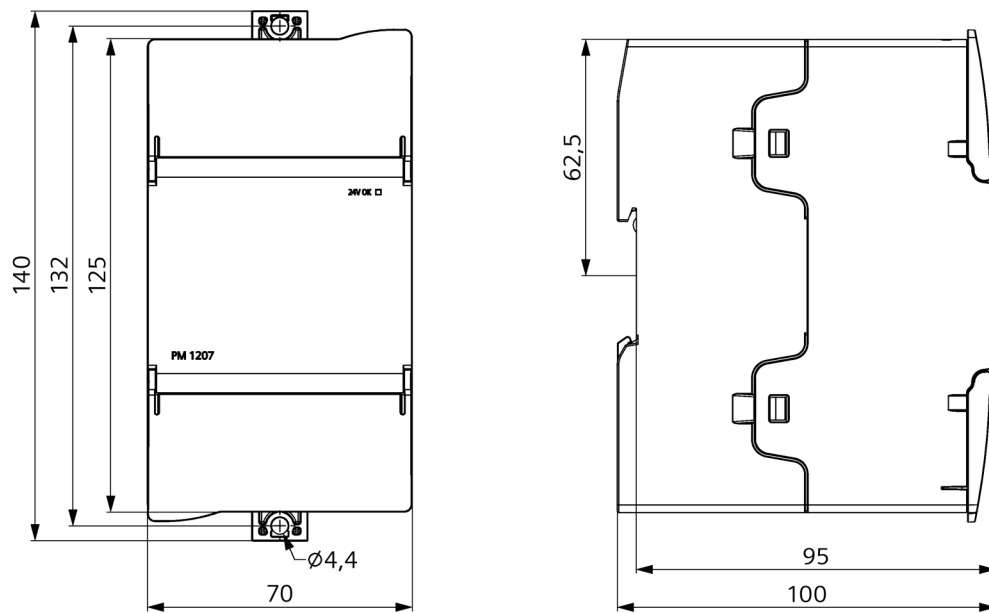


Figure 2-4 Dimension drawing

	PM 1207 24 V/5 A 6EP3333-4SB00-3AX0	PM 1207 Ex 24 V/5 A 6EP3333-4SC00-3AX0
Dimensions (W × H × D) in mm	70 × 125 × 100	
Weight	Approx. 0.45 kg	

Mounting/removal

! WARNING**Installing the device in a housing or a control cabinet**

SITOP PM 1207 Power supplies are built-in devices. They must be installed in a housing or control cabinet where only qualified personnel have access.

The device can be mounted in a control cabinet on standard mounting rails (see Chapter Mechanical system (Page 31))

Mounting

The device must be mounted in such a way that the input and output terminals are at the bottom. A clearance of at least 25 mm must be maintained above and below the device (max. cable duct depth 50 mm).

To mount the device on a standard mounting rail, position it with the mounting rail guide at the upper edge of the mounting rail and press down to lock it into place. If this is too difficult to snap on, press the slider ⑤ at the same time, as described under "Removal".

For wall mounting on a flat surface, place the device with the sliders ⑥ (extend the slider until it snaps into place) over the holes and fix in place using suitable screws. For the holes, see Figure 3-2 Wall mounting (Page 16)

Removing

To remove, pull up the slider ⑤ using a screwdriver (see Figure 3-1 Mounting/removal (Page 16)) and disengage the device at the bottom edge of the standard mounting rail. Then you can remove the device from the upper edge of the standard mounting rail.

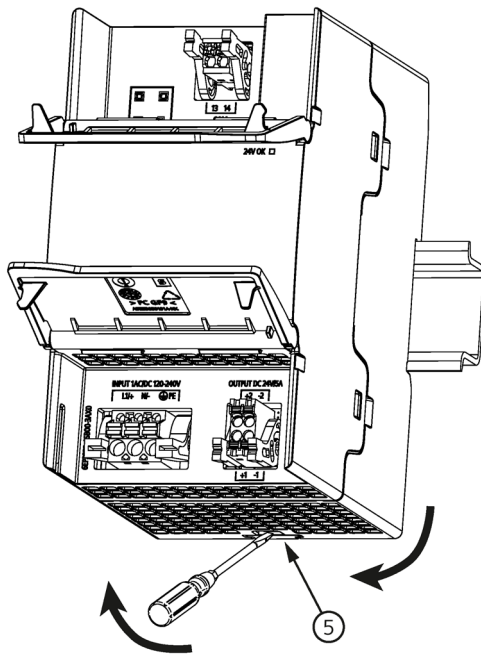


Figure 3-1 Mounting/removal

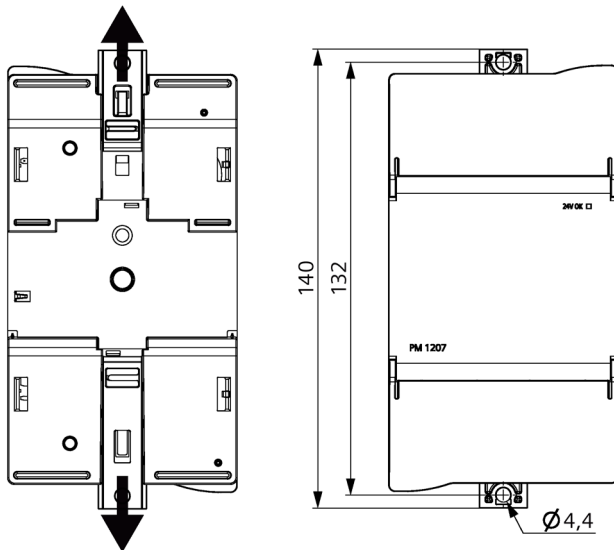


Figure 3-2 Wall mounting

<p>⚠ WARNING</p> <p>Use in hazardous zones</p> <p>When installing the device in a hazardous zone (6EP3333-4SC00-3AX0: II 3G Ex ec IIC T3 Gc) this must be installed in a distribution box with degree of protection IP54 or higher. This distribution box must comply with the requirements of IEC/EN 60079-0/GB/T3836.1-2021 and must require a tool for opening.</p>
--

Mounting position, mounting clearances

The device is mounted on standard mounting rails. The certified standard mounting position of the device is vertical, and to ensure correct cooling, it must be mounted so that the input and output terminals are at the bottom.

A clearance of at least 25 mm must be maintained above and below the device (max. cable duct depth, 50 mm).

Lateral clearances do not have to be maintained.

Output current as a function of the ambient temperature and installation height

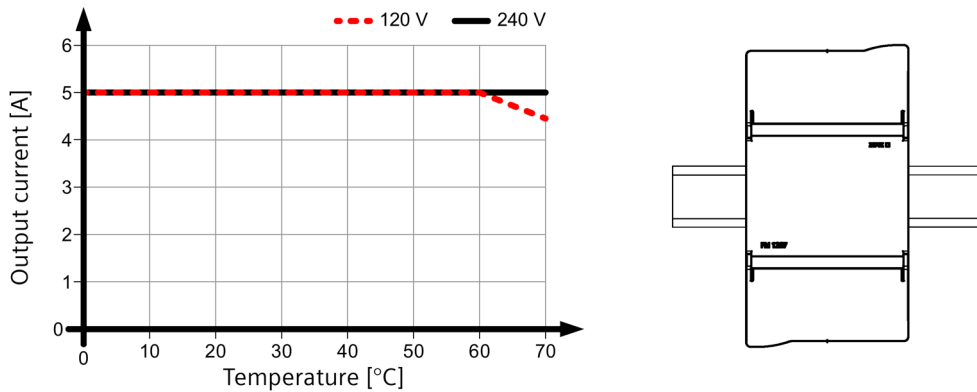


Figure 4-1 Output current in the standard mounting position

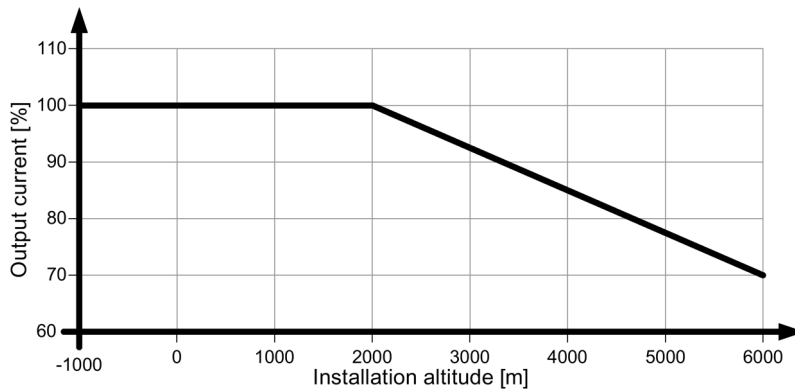


Figure 4-2 Installation height derating

For details, see Chapter Ambient conditions (Page 37)

4.1 Other mounting positions

For mounting positions that deviate from the standard mounting position, derating factors (reduction of the output power or the permissible ambient temperature) must be observed in accordance with the following diagrams.

Note

In the case of mounting positions that deviate from the standard mounting position, reduced mechanical resistance of the devices against vibration and shock must be expected.

Particularly when installing on a vertically fastened standard mounting rail, additional measures may be required, e.g. to prevent the device from slipping on the standard mounting rail.

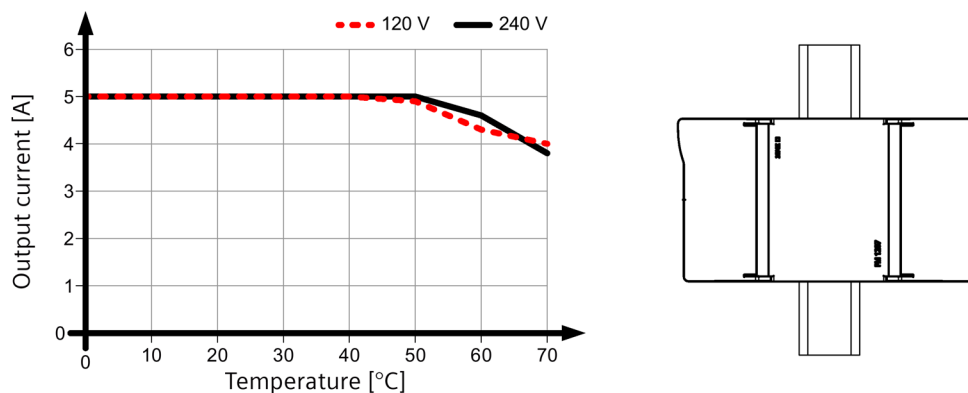


Figure 4-3 Mounting position 1

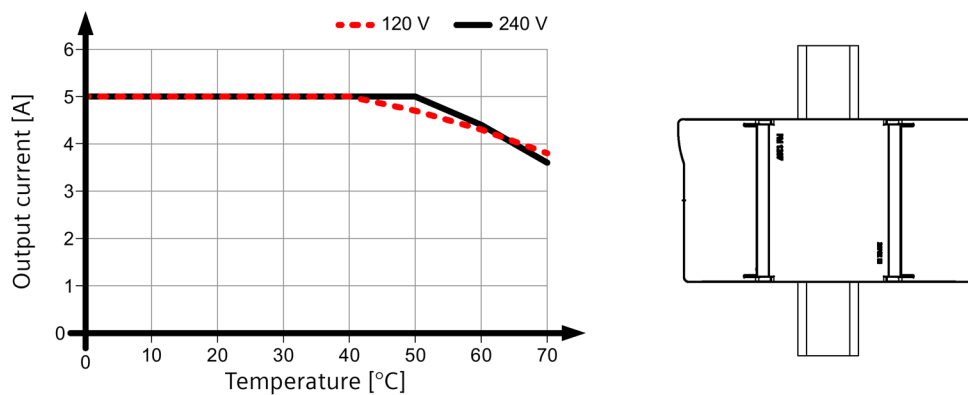


Figure 4-4 Mounting position 2

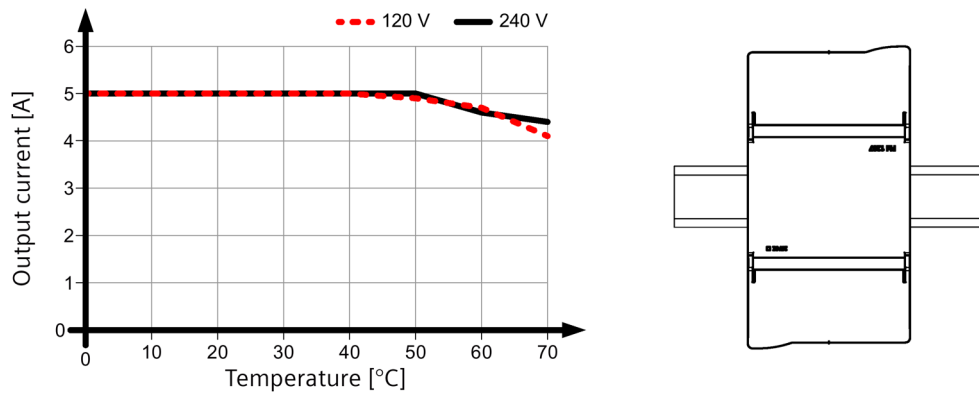


Figure 4-5 Mounting position 3 (input terminals at the top)

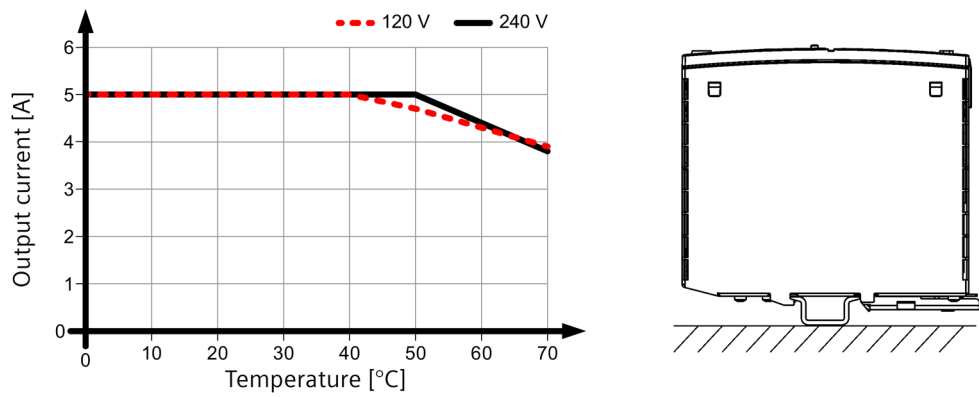


Figure 4-6 Mounting position 4

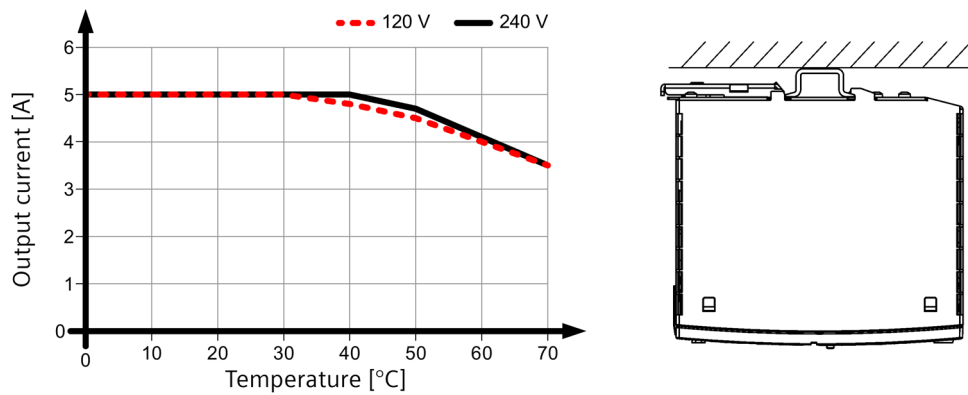


Figure 4-7 Mounting position 5

4.1 Other mounting positions

! WARNING
Hazard due to electric shock
Before installation or maintenance work can begin, the system's main switch must be switched off and measures taken to prevent it being switched on again. If this instruction is not observed, touching live parts can result in death or serious injury.

Use copper wire approved for 90 °C for the wiring.

5.1 Line-side connection

The PM 1207 power supply is designed for connection to a 1-phase AC line voltage with a rated voltage 120 - 240 V AC, 50 - 60 Hz or a DC supply with 120 - 240 V DC.

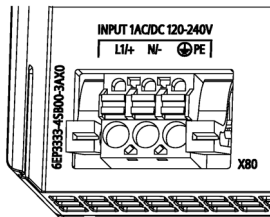


Figure 5-1 Line-side connection

The line supply is connected via terminals L1/+, N/-, and PE (see Figure 5-1 Line-side connection (Page 21)) and must be implemented according to IEC 60364. A protective device (miniature circuit breaker or circuit breaker) and a disconnection unit for the power supply must be provided. A ground-fault circuit interrupter is not permissible against indirect contact as the only protective measure. This applies for the complete line supply protected by the ground-fault circuit interrupter.

Protection

PM 1207	Line-side protection
PM 1207 24 V/5 A 6EP3333-4SB00-3AX0 PM 1207 Ex 24 V/5 A 6EP3333-4SC00-3AX0	Miniature circuit breaker characteristic B/C: 4 - 16 A (for UL: UL489-listed/category DIVQ)

The protective conductor of the line supply must be connected at the PE terminal.

Other country-specific regulations may have to be observed when installing the device.

NOTICE

Country-specific regulations must be observed when installing.

Note

For operation on a DC power system (DC), the plus pole (+) must be connected to L1/+ and the minus pole (-) to N/-.

5.2 Output-side connection

PM 1207 Power supplies provide an isolated (= non-grounded) SELV (ES1) output voltage (Safety Extra Low Voltage (Electrical energy source class 1)). The output of the power supply is no-load, overload, and short-circuit proof. If an overload occurs, the electronic current limiting function limits the output current to a maximum value (see Chapter Technical data (Page 25)).

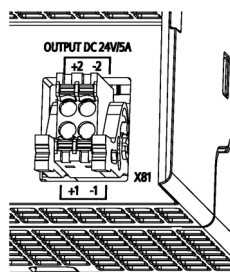


Figure 5-2 Output-side connection

The output voltage is connected via the "+" and "-" terminals at the output of the power supply (see Figure Output-side connection (Page 23)). Ensure that the output cables are dimensioned correctly for the maximum output current rms value and fused accordingly.

The subsequent digit, e.g.: "+1" designates the unique terminal connection, therefore simplifying correct wiring.

Note

If the safety concept of the plant or system specifies that the DC output circuit should be grounded (PELV), then it is permissible that the output voltage of the SITOP power supply is grounded. In this case, ideally, the grounding at the output should be directly connected from terminal "-" of the power supply to a suitable connection point of the protective conductor system (PE) of the plant or system.

5.3 Connecting the diagnostic interface

Diagnostic interface COM (terminals "13" and "14") is an NO contact and allows information about the operating state of the device to be processed. Connect the diagnostic interface for evaluation, e.g. with an automation system.

The diagnostic interface, which is unidirectional, can only send data to the higher-level control and evaluation system. Data cannot be received.

For more information, see document Diagnostic interface (<https://support.industry.siemens.com/cs/ww/en/view/109986608>).

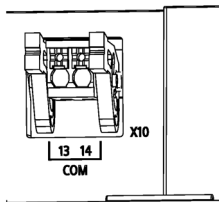


Figure 5-3 Diagnostic interface

NOTICE

It is not permissible that the diagnostic interface is connected on the primary side!
It is only used for communications!

Note

The contact rating is 30 V DC/0.1 A.

The diagnostic interface must fully comply with the requirements relating to SELV (ES1) circuits.

Note

The terminals are implemented as push-in connection system. The terminal must first be opened for smaller conductor cross-sections and for flexible conductors without conductor end sleeves. To do this, insert an appropriate slotted screwdriver into the square slot of the appropriate connection.

Technical data

Note

Technical data apply for a rated input voltage, rated load and 25 °C ambient temperature, if nothing else is specified.

6.1 Input

	PM 1207 24 V/5 A 6EP3333-4SB00-3AX0	PM 1207 Ex 24 V/5 A 6EP3333-4SC00-3AX0
Rated voltage $U_{in \text{ rated}}$	1 AC: 120 - 240 V; DC: 120 - 240 V	
Voltage range	1 AC: 108 - 264 V; 108 - 264 V DC 108 - 275 V DC (UL: 108 - 264 V)	
Extended voltage range with derating:	1 AC: 85 - 108 V, 67 % $I_{out \text{ rated}}$ DC: 99 - 108 V, 90 % $I_{out \text{ rated}}$	
Wide-range input	Yes	
Switch-in/switch-out threshold, typical	70 V / 55 V	
Power failure buffering at $I_{out \text{ rated}}$, min	20 ms	
Power-failure buffering	at 120 V / 240 V	
Rated line frequency	50 - 60 Hz	
Line frequency range	47 - 63 Hz	
Input current at the rated input voltage of 120 V	1.9 A AC / 1.2 A DC	
Input current at a rated input voltage of 240 V	1.1 A AC / 0.55 A DC	
Inrush current limiting (25 °C), max.	45 A	
I^2t , at 120 V AC, max.	0.5 A ² s	
I^2t , at 240 V AC, max.	1.8 A ² s	
Integrated input fuse	T 3, 16 A fuse	
Protection/fusing in the line feeder cable (IEC 898)	Miniature circuit breaker characteristic B/C, 4 - 16 A (for UL: UL489-listed/category DIVQ)	
Power consumption (active power) at full load	136 W	
Overvoltage strength	300 V AC for 30 seconds	

6.1 Input

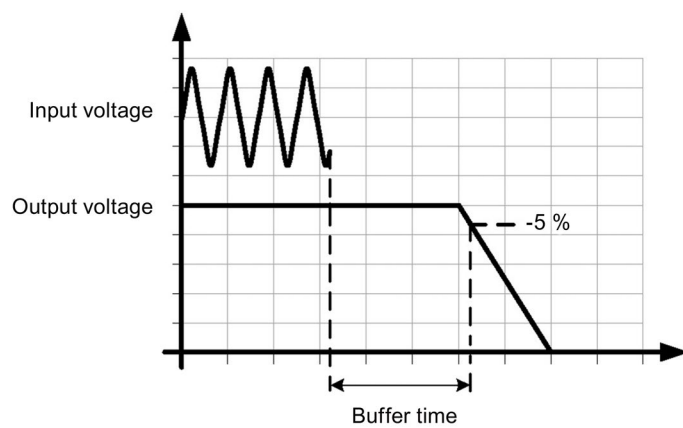


Figure 6-1 Power failure buffering

6.2 Output

	PM 1207 24 V/5 A 6EP3333-4SB00-3AX0	PM 1207 Ex 24 V/5 A 6EP3333-4SC00-3AX0
Output	Regulated, isolated DC voltage	
Rated voltage $U_{out\ rated\ DC}$	24 V	
Total tolerance, static \pm	1.5 %	
Static line regulation, approx. \pm	0.1 %	
Static load regulation, approx. \pm	0.2 %	
Residual ripple Peak-peak, max.	150 mV	
Spikes peak-peak, max. (band- width, 200 MHz)	50 mV	
Output voltage can be adjusted	No	
Operating display	LED green for 24 V OK	
Signaling	Diagnostic interface	
Response when switching on/off	Overshoot of $U_{out} < 100\text{ mV}$	
Starting delay, max.	100 ms	
Starting delay, typ.	50 ms	
Voltage rise time for 120 V / 240 V AC max.	220 ms	
Voltage rise time for 120 V / 240 V AC typ.	220 ms	
Rated current $I_{out\ rated}$	5 A	
Current range	0 - 5 A	
• Remark	60 ... 70 °C derating: 3 % $I_{out\ rated}/K$	
Active power output, typ.	120 W	
Can be connected in parallel to increase the power rating	Yes	
Number of devices that can be connected in parallel to increase the power rating, units	2	
Output characteristic	See Figure 6-3 Output characteristic (Page 28)	
Capacitive load, max.	2 mF/A	

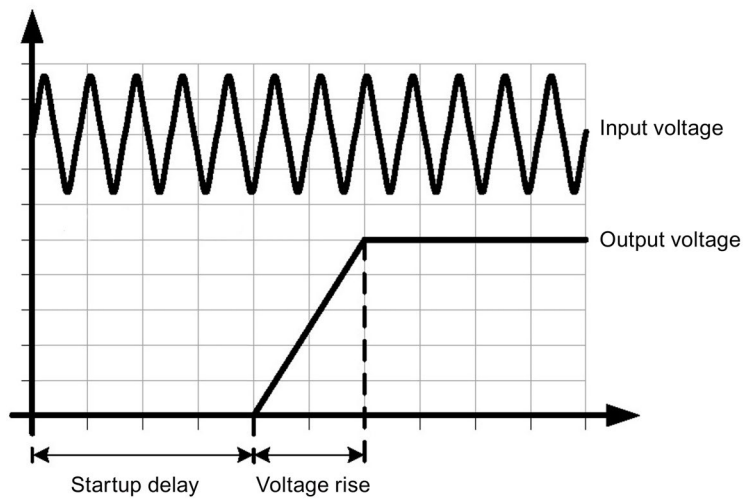


Figure 6-2 Startup delay/voltage rise

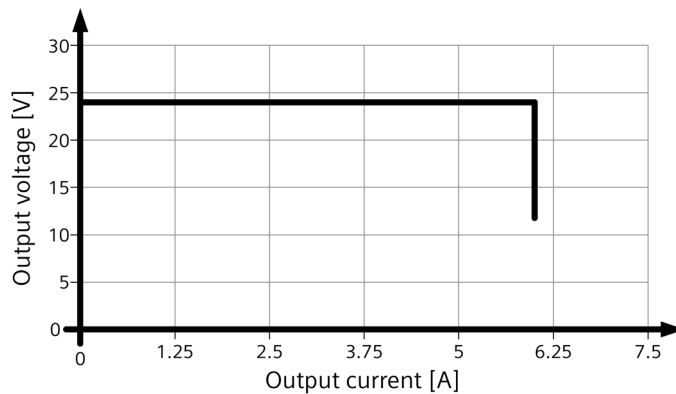


Figure 6-3 Output characteristic

The devices supply a constant output voltage until the current limit is reached. In the event of an overload, the output current and the output voltage are reduced.

When the output voltage falls below approx. 60 % of the rated output voltage, the devices switch off and then automatically restart. This response is repeated as long as the overload condition is present.

6.3 Efficiency

	PM 1207 24 V/5 A 6EP3333-4SB00-3AX0	PM 1207 Ex 24 V/5 A 6EP3333-4SC00-3AX0
Efficiency at U_{out} rated, I_{out} rated 120 V / 240 V AC approx.	88.1 % / 89.2 %	
Power loss at U_{out} rated, I_{out} rated 120 V / 240 V AC approx.	16 W / 14 W	
Power loss when idling 120 V / 240 V AC approx.	1.4 W / 2.4 W	

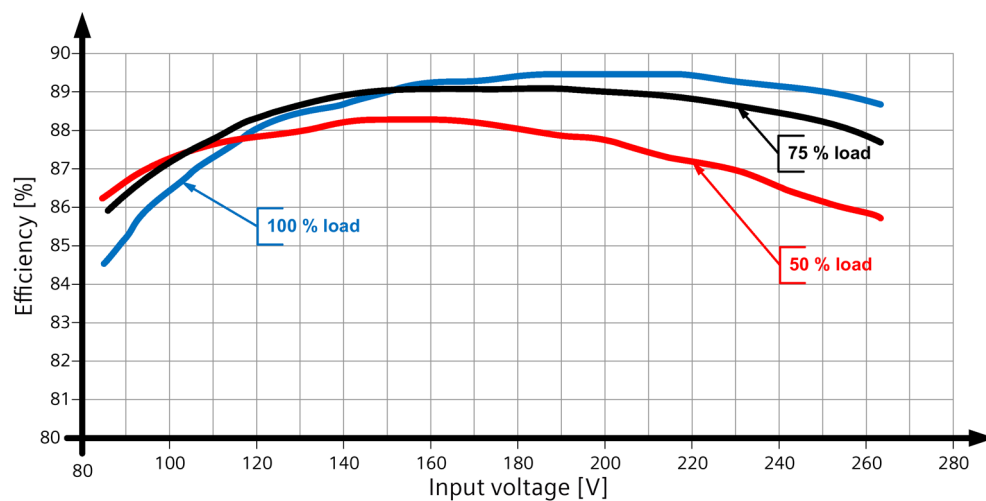


Figure 6-4 Efficiency

6.4 Closed-loop control

	PM 1207 24 V/5 A 6EP3333-4SB00-3AX0	PM 1207 Ex 24 V/5 A 6EP3333-4SC00-3AX0
Dyn. line regulation ($U_{in rated} \pm 15\%$), max.	1.5 % U_{out}	
Dyn. load regulation ($I_{out}: 10/90/10\%$), max.	1.5 % U_{out}	
Dyn. load regulation ($I_{out}: 10/90/10\%$), typ.	1.5 % U_{out}	
Load step regulation time 10 to 90 %, max.	1 ms	
Load step regulation time 10 to 90 %, typ.	1 ms	
Load step regulation time 90 to 10 %, max.	1 ms	
Load step regulation time 90 to 10 %, typ.	1 ms	

6.5 Protection and monitoring

	PM 1207 24 V/5 A 6EP3333-4SB00-3AX0	PM 1207 Ex 24 V/5 A 6EP3333-4SC00-3AX0
Output overvoltage protection	in the case of an internal fault $U_{out} < 32\text{ V}$	
Current limitation, typ.	5.9 A	
Short-circuit protection	Electronic trip, automatic restart (hiccup)	

6.6 MTBF

	PM 1207 24 V/5 A 6EP3333-4SB00-3AX0	PM 1207 Ex 24 V/5 A 6EP3333-4SC00-3AX0
Mean Time Between Failures	SN29500: > 1100000 h at 40 °C, rated load, 24 h operation	

6.7 Mechanical system

	PM 1207 24 V/5 A 6EP3333-4SB00-3AX0	PM 1207 Ex 24 V/5 A 6EP3333-4SC00-3AX0
Connection system	Push-in terminal (can be removed)	
Connections: Line input	L1/+, N/-, PE: One push-in terminal (3-pole terminal block) each for 0.2 - 2.5 mm ² solid/finely stranded	
Connections: Output	Two push-in terminals each for - and + (4-pole terminal block) for 0.14 - 1.5 mm ² solid/finely stranded	
Connections: Auxiliary contacts	Diagnostic interface 13, 14: One push-in terminal (2-pole terminal block) each for 0.14 - 1.5 mm ² solid/finely stranded	
Width of the housing	70 mm	
Height of the housing	125 mm	
Depth of the housing	100 mm	
Mounting width	70 mm	
Mounting height	175 mm	
Weight, approx.	0.45 kg	
Product feature of the housing: housing that can be lined up next to one another	Yes	
Type of mounting: Wall/panel mounting	Yes	
Type of mounting: Rail mounting	Yes	
Type of mounting: S7 rail mounting	No	
Mounting	Can be snapped onto standard TH35-15/7,5 mounting rails (EN 60715)	

6.8 Accessories

	PM 1207 24 V/5 A 6EP3333-4SB00-3AX0	PM 1207 Ex 24 V/5 A 6EP3333-4SC00-3AX0
Electrical accessories	Redundancy module, buffer module, selectivity module	

6.9 Dimension drawing

See chapter Dimensions and weight (Page 14)

CAD data that can be downloaded from the Internet:

6EP3333-4SB00-3AX0

(http://www.automation.siemens.com/bilddb/index.aspx?objKey=G_KT01_XX_02104)

6EP3333-4SC00-3AX0

(http://www.automation.siemens.com/bilddb/index.aspx?objKey=G_KT01_XX_02122)

Safety, approvals, EMC

7.1 Safety

	PM 1207 24 V/5 A 6EP3333-4SB00-3AX0	PM 1207 Ex 24 V/5 A 6EP3333-4SC00-3AX0
Primary/secondary galvanic isolation	Yes	
Galvanic isolation	SELV (ES1) output voltage U_{out} according to EN 61204-7 transformer according to IEC 61558-2-16 in conjunction with IEC 61558-1	
Protection class	Class I	
Degree of protection (EN 60529)	IP20	
Leakage current, max.	3.5 mA	
Test voltage	See Table 7-1 Test voltage (Page 34)	

7.2 Test voltage

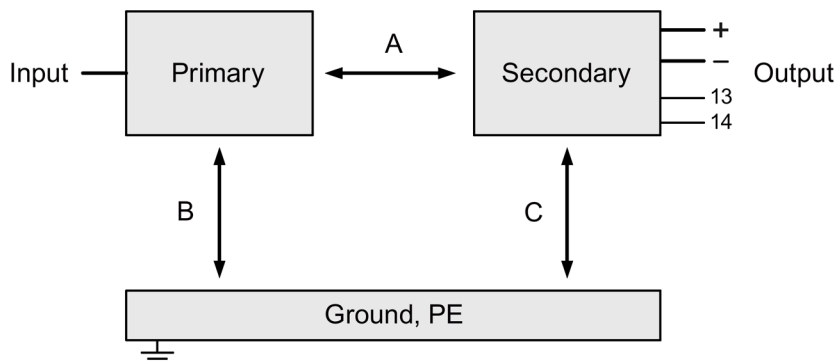


Figure 7-1 Test voltage diagram

Only the manufacturer can perform the type test and production test; users can also perform the field test.

Preconditions for performing the field test:

Tests (A) & (B)

- Connect the input terminals with one another (L1/+, N/-, PE)
- Connect the output terminals, diagnostic interface and PE with one another

Test (C)

- Connect the output terminals and diagnostic interface with one another and measure with respect to PE

Table 7-1 Test voltage

	Test time	Prim ↔ sec (A)	Prim ↔ PE (B)	Sec ↔ PE (C)
Type test	60 s	4000 V DC	2500 V DC	-
Production test	1 s	3600 V DC	2700 V DC	900 V DC
Field test	1 s	3600 V DC	2700 V DC	900 V DC

Remark:

Tripping current for DC measurement: max. 10 mA

7.3 Approvals

	PM 1207 24 V/5 A 6EP3333-4SB00-3AX0	PM 1207 Ex 24 V/5 A 6EP3333-4SC00-3AX0
CE marking	Yes (2014/35/EU, 2014/30/EU and 2011/65/EU)	Yes (2014/35/EU, 2014/30/EU, 2011/65/EU and 2014/34/EU)
CB certificate	Yes (IEC 62368-1, IEC 61010-1, IEC 61010-2)	
UL/cUL approval	cULus-listed (UL 61010, CSA 22.2 No. 107.1), File E143289	
cCSAus approval	Yes, CSA C22.2 No. 62368-1, UL 62368-1	
Explosion protection	-	Yes
ATEX approval	-	II 3G Ex ec IIC (T4...T3) Gc -25 °C ≤ T _{amb} ≤ 55 °C: T4 -25 °C ≤ T _{amb} ≤ 70 °C: T3 (UL 24 ATEX 3302 X)
IECEX approval	-	II 3G Ex ec IIC (T4...T3) Gc -25 °C ≤ T _{amb} ≤ 55 °C: T4 -25 °C ≤ T _{amb} ≤ 70 °C: T3 (IECEX ULD 24.0029 X)
cULus HazLoc approval	-	CLASS I, DIV.2, GR A,B,C,D,TX -25 °C ≤ T _{amb} ≤ 55 °C: T4 -25 °C ≤ T _{amb} ≤ 70 °C: T3 (E330455)
CCC HazLoc approval	-	Available soon
FM approval	-	Available soon
SEMI F47	Available soon	
Marine approvals	DNV, available soon: ABS, LRS, BV, NKK, RINA, CCS, KR	
UKCA marking	Yes	
RCM approval	Yes	
EAC approval	Yes	
BIS certificate	Available soon	

7.4 EMC

		PM 1207 24 V/5 A 6EP3333-4SB00-3AX0	PM 1207 Ex 24 V/5 A 6EP3333-4SC00-3AX0
Electrostatic discharge	EN 61000-4-2	8 kV contact, 8 kV air	
Electromagnetic fields	EN 61000-4-3	80 ... 1000 MHz 10 V/m 1400 ... 2000 MHz 10 V/m 2000 ... 2700 MHz 10 V/m 895 ... 905 MHz and 1.89 GHz 10 V/m	
High-speed transient disturbance variables (burst)	EN 61000-4-4	4 kV at line connections 2 kV at the DC output 1 kV at the diagnostic interface	
Surge voltages	EN 61000-4-5	1 kV symmetrical at line connections 2 kV unsymmetrical at line connections 500 V symmetrical on DC output cables and diagnostic interface 1 kV unsymmetrical on DC output cables and diagnostic interface	
High-frequency fields	EN 61000-4-6	10 V; 0.15 ... 80 MHz	
Magnetic fields	EN 61000-4-8	30 A/m; 50 Hz	
Voltage dips	EN 61000-4-11	100% for 20 ms, 60% for 200 ms, 30% for 500 ms	
Voltage interruptions	EN 61000-4-11	100% for 5000 ms	
Emitted interference	EN 55032	Class B	
Line harmonics limitation	EN 61000-3-2	Class A	
Generic standards	EN 61000-6-2	Immunity for industrial environments	
	EN 61000-6-3	Emission for residential areas	

Ambient conditions

	PM 1207 24 V/5 A 6EP3333-4SB00-3AX0	PM 1207 Ex 24 V/5 A 6EP3333-4SC00-3AX0
Ambient temperature	-25 ... 70 °C for natural convection (self convection)	
	Tested according to: <ul style="list-style-type: none"> • EN 60068-2-1 Cold • EN 60068-2-2 Dry heat • EN 60068-2-78 Humid heat, constant • EN 60068-2-14 Temperature change 	
Transport and storage temperature	-40 ... 85 °C	
	Tests (packed for shipping) according to: <ul style="list-style-type: none"> • EN 60068-2-1 Cold • EN 60068-2-2 Dry heat • EN 60068-2-30 Humid heat, cyclic 	
Humidity class	Climatic class 3K3 acc. to EN 60721, 5 - 95 % no condensation	
Mechanical stress in operation	Tested according to: <ul style="list-style-type: none"> • EN 60068-2-6 vibration, test Fc: 3.5 mm deflection in the range 5 – 8.4 Hz 2 g acceleration in the range 8.4 – 150 Hz • EN 60068-2-27 shock, test Ea: acceleration 150 m/s², test duration 11 ms 	
Damaging gases	Tested according to: <ul style="list-style-type: none"> • EN 60068-2-42 sulfur dioxide • EN 60068-2-43 hydrogen sulfide 	
Atmospheric pressure	Operation: <ul style="list-style-type: none"> • 1080 - 795 hPa (≤ 2000 m) • For operation at altitudes of 2000 m up to 6000 m above sea level: output must be derated by -7.5% / 1000 m or the ambient temperature must be reduced by 5 K / 1000 m see Figure 4-2 Installation height derating (Page 17) • Overvoltage category: II up to 2000 m (IEC 61204-7) I from 2000 m up to 6000 m (IEC 61204-7) Storage: <ul style="list-style-type: none"> • 1080 - 660 hPa (≤ 3500 m) 	

9.1 Parallel connection to increase the power rating

A parallel connection to increase the power is required if one power supply alone cannot supply the total power of a system. To increase the power, in most cases, identical power supplies can be electrically connected directly in parallel (see Chapter Technical data/ Output (Page 27) / Parallel connection to increase power).

The following general measures should be observed:

- The power supplies connected in parallel must be switched on simultaneously with a common switch in the line feeder cable (e.g. with the main switch available in control cabinets).
- The conductors connected to each power supply at terminals "+" and "-" must have the same impedance up to a common external connection point (terminal strip), i.e. they must have the same length and the same cross-section.

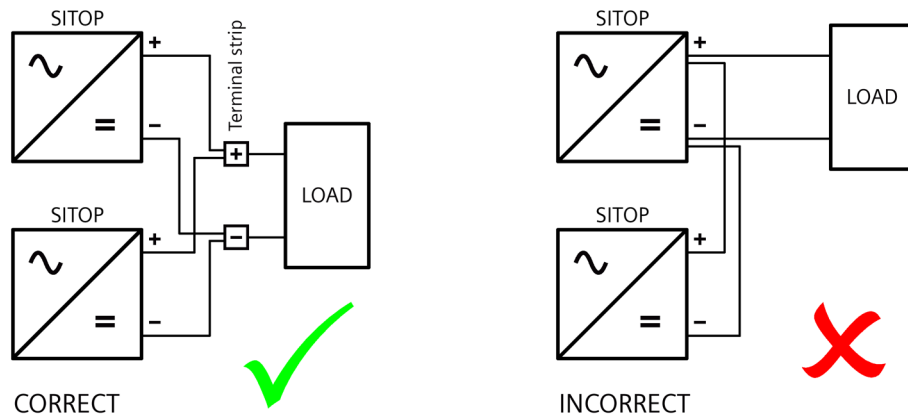


Figure 9-1 Parallel connection of two power supplies

- The power supplies connected in parallel must be adjusted to have the same output voltage.
- It is not permissible that dynamic power reserves, such as *Extra Power* and *Power Boost*, are taken into account a multiple number times when configuring the system.

NOTICE

Protective circuit when connecting more than two power supplies in parallel

When connecting more than two power supplies in parallel, additional measures must be taken to prevent high reverse currents in the event of a secondary device fault. For this purpose, a suitable protective circuit (e.g. decoupling diode or DC-capable circuit breaker) must be installed between each "+" terminal of the power supply and the common connection point.

9.1 Parallel connection to increase the power rating

For a direct electrical parallel connection without support of the current distribution, the output voltages measured in no-load operation for the power supplies that are not yet connected in parallel should not deviate by more than a maximum of 50 mV. This usually corresponds to the factory setting.

Procedure to precisely align the output voltages:

1. Connect the "-" terminals of the devices to be connected in parallel
2. When the devices are operating under no load, measure the voltage difference between the "+" terminals that have not yet been connected.
3. Adjust the output voltages of the devices so that the voltage difference between the devices is less than 50 mV

Parallel connection with passive current distribution using an inclined output characteristic

In a parallel connection, to avoid that one power supply is continually operating with full load and the other only with partial load, for some device types, a passive current distribution can be realized using an output characteristic that can be switched over. For the inclined output characteristic for parallel operation, the output voltage is reduced as the output current increases. If, in a parallel connection, the output voltage of one device falls below the output voltage of the other, then the other device also participates in supplying the load. This prevents a device from being operated continuously at full load. The more precisely the output voltages of the devices connected in parallel are aligned to one another, the more even the current distribution among the devices. However, as a result of the inclined output characteristic, the output voltage of the parallel connection does not remain constant across the complete load range.

Procedure for the parallel connection with passive current distribution:

1. Align the output voltages of all devices as precisely as possible with one another when operating without any load
2. For all devices, select the inclined output characteristic for parallel operation
3. Switch off the devices
4. Establish the parallel wiring at the output terminals
5. Switch on all of the devices using one common switch

Assuming that the function is supported by the devices, more information to switch over the output characteristic is provided in Chapter Description, design of the device, dimension drawing (Page 9).

9.2 Series connection for increased voltage

To implement an output voltage of 48 V DC, two identical 24 V power supplies can be connected in series. Depending on the grounding point of the secondary output voltage, voltages of +48 V, ± 24 V or -48 V can therefore be realized.

To guarantee safe and reliable operation of the power supplies in all operating states, for the series connection, the subsequent wiring using two redundancy modules SITOP RED1200 is recommended.

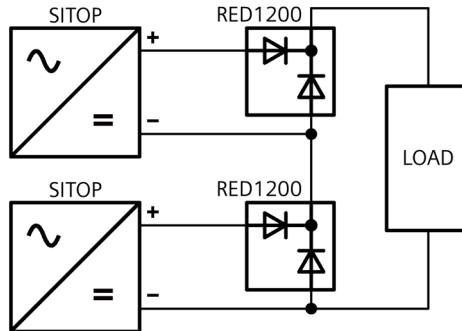


Figure 9-2 Two power supplies in a series connection with SITOP RED1200 redundancy module

⚠ WARNING
SELV (ES1) in the case of fault, not guaranteed
When connecting two power supplies in series, SELV (ES1) according to EN 61204-7, cannot be guaranteed in the case of a fault.

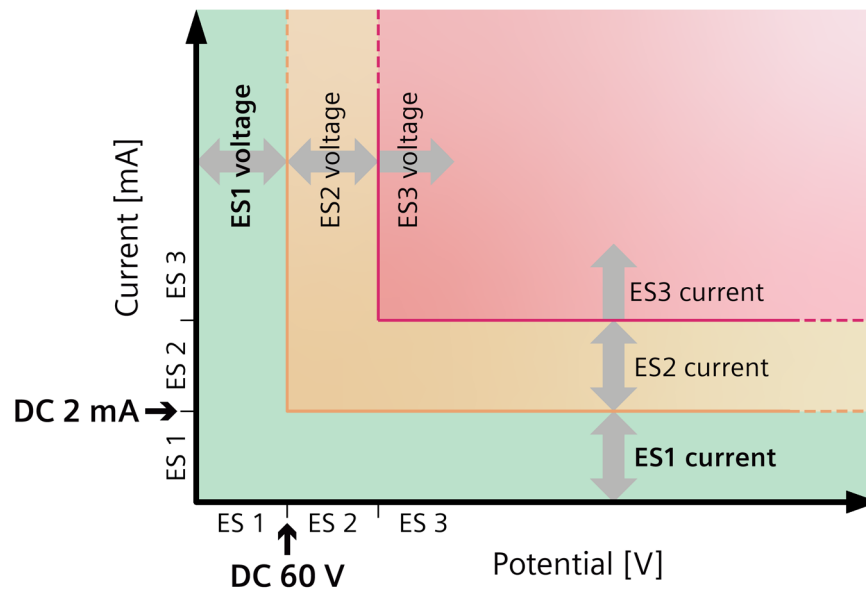


Figure 9-3 Representation of the ES limit values for voltage and current

9.3 Overload protection in the 24 V output circuit

If an overload occurs, the electronic current limiting function of the 24 V power supply limits the output current to a maximum value (see Chapter Technical data (Page 25)). The output cables are protected against a thermal overload if they are dimensioned corresponding to the maximum rms output current, or protected using additional components (for example, miniature circuit breaker, fuses).

However, a load circuit that fails as a result of overload, for instance, should frequently be reliably and quickly identified and specifically switched off before the power supply goes into current-limiting mode (in current-limiting mode, the supply voltage would also be reduced for all of the remaining 24 V loads).

SITOP PSE200U, SITOP SEL1200 and SITOP SEL1400 selectivity modules and the SITOP SEL1600 selectivity system are available to monitor 24 V branches for overload and short-circuit.

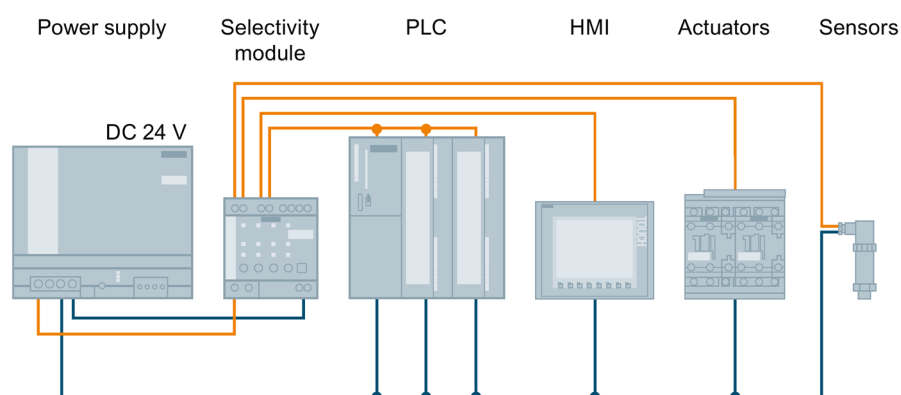


Figure 9-4 Electronic protection of 24 V loads shown as example with the SITOP PSE200U selectivity module

Brief current peaks, e.g. as a result of a high inrush current, are permitted, and branches with a longer overload are switched into a no-current condition. This is also ensured for cables in a high-ohmic condition and for short circuits that slowly develop over time.

When an output fails, the fault is signaled using a group signal contact or as a single channel signal (PSE200U, SEL1200, SEL1400) as well as via an IO-Link interface (SEL1600) and the branch of the module involved is signaled using an LED.

For variants with single-channel signaling, function blocks for evaluation purposes are available for SIMATIC S7-1200/1500/300/400, for STEP 7 Classic and TIA Portal at no charge.

You can find more information at:

Manual SITOP PSE200U selectivity module

(<https://support.industry.siemens.com/cs/ww/en/view/108989004>)

Manual SITOP SEL1200 and SEL1400 selectivity modules

(<https://support.industry.siemens.com/cs/ww/en/view/109768675>)

Manual SITOP selectivity system SEL1600

(<https://support.industry.siemens.com/cs/ww/en/view/109815738>)

9.4 Protection against short-time voltage dips

For a drop in the line-side supply voltage, the 24 V power supply still maintains the output voltage for a short time in the millisecond range (see Chapter Technical data (Page 25)).

For line supplies that manifest frequent brief voltage dips, in order to increase the power supply reliability, it may make sense to increase the power failure buffering time in the device using an additional SITOP buffer module.

The SITOP buffer module is simply connected in parallel to the power supply output using two conductors.

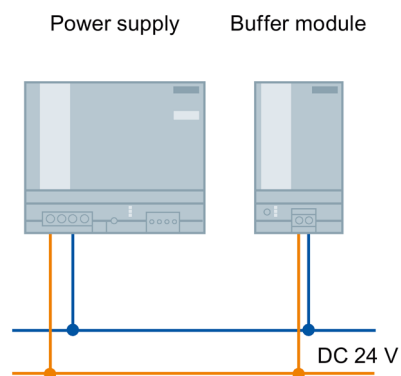


Figure 9-5 Buffering brief power failures shown as example using the SITOP PSE201U buffer module

As energy storage device, it uses maintenance-free capacitors and automatically supplies 24 V if the line voltage fails. The load is buffered without any interruption. Several buffer modules can be connected in parallel to extend the buffer time.

You can find more information at:

Manual SITOP Expansion Modules

(<https://support.industry.siemens.com/cs/ww/en/view/109768676>)

9.5 Protecting against longer power failures

Sudden and longer failures of the line supply voltage can result in undefined states and significant danger as a result of the associated failure of the plant or system control. The SITOP power supply product portfolio includes various DC-UPS solutions to prevent the failure of the 24 V power supply voltage.

Power supply failures up into the minutes range can be buffered using the maintenance-free SITOP UPS500 DC-UPS modules based on capacitors (Figure 9-6 24 V buffering shown as example to allow process data to be saved and controlled shutdown of PCs (Page 44)).

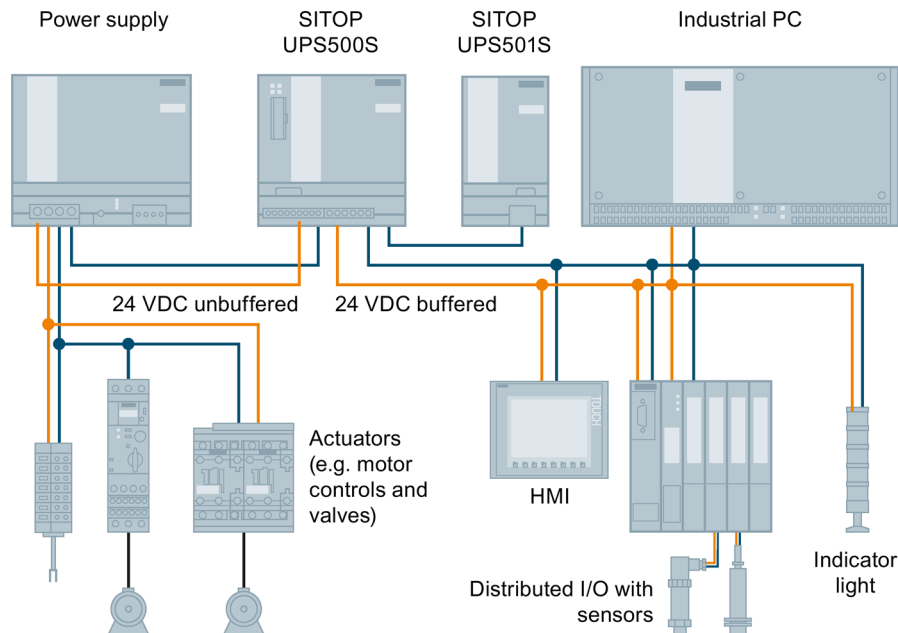


Figure 9-6 24 V buffering shown as example to allow process data to be saved and controlled shutdown of PCs

Using the free-of-charge SITOP DC-UPS software tool, DC-UPS systems can be simply integrated into PC-based automation solutions. This supports further processing of the status signals and safely running down the PC.

You can find more information at:

Manual, DC UPS with capacitors

(<https://support.industry.siemens.com/cs/ww/en/ps/18042/man>)

Using the SITOP UPS1600 DC UPS and battery modules SITOP BAT1600 or SITOP UPS1100, buffer times in the range of hours can be implemented. Intelligent battery management using Energy Storage Link automatically detects the energy storage device, and ensures optimum temperature-controlled charging and continuous monitoring. The UPS1600 with its digital inputs/outputs as well as optional USB interface or Ethernet/PROFINET port can be flexibly integrated into the widest range of automation applications.

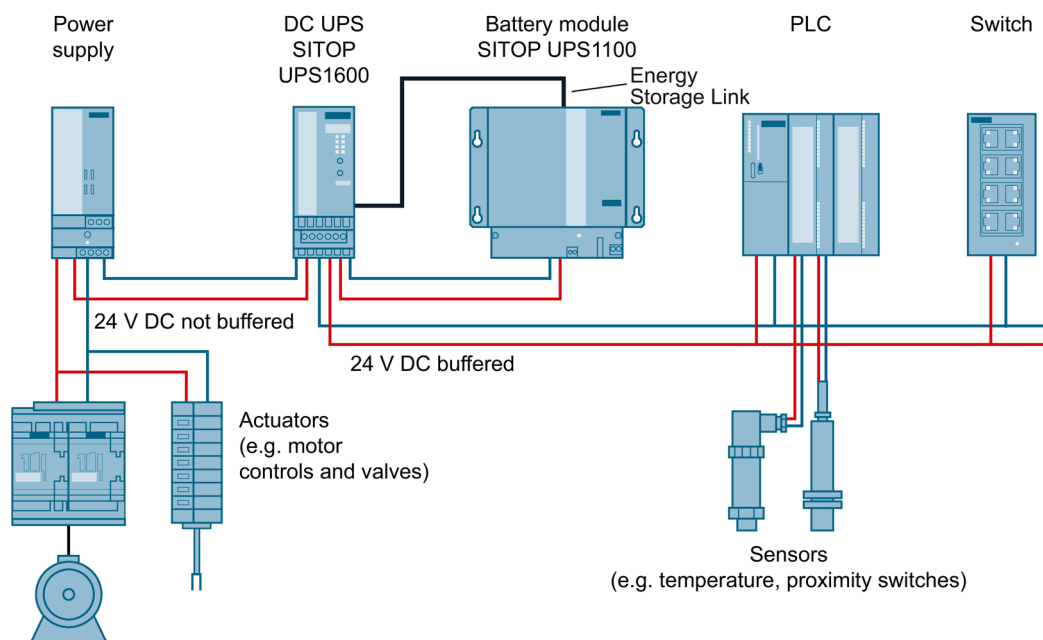


Figure 9-7 24 V buffering shown as example with SITOP UPS1600 to maintain communications, signaling functions, sensor measured values and position values

For open, PC-based automation systems, configuration and monitoring is realized using the free-of-charge SITOP Manager, or for devices with an older software release, using PC software SITOP UPS Manager (compatibility list, see DC-UPS Manual SITOP UPS1600/BAT1600/UPS1100 (<https://support.industry.siemens.com/cs/ww/en/view/84977415>)). This allows PC responses to the operating states of the DC UPS to be freely selected – and offers comprehensive diagnostic functions.

For TIA-based automation systems, the UPS1600 is engineered using the TIA Portal. Special function blocks for SIMATIC S7-300/400/1200 and S7-1500 are available at no charge, and make it easy to integrate operating and diagnostics information into STEP 7 user programs. Preconfigured UPS faceplates for WinCC visualization can be downloaded at no charge.

You can find more information at:

Manual DC-USV SITOP UPS1600/BAT1600/UPS1100

(<https://support.industry.siemens.com/cs/ww/en/view/84977415>)

Environment

The devices are in conformance with RoHS.

Only substances in conformance with PWIS are used (paint-wetting impairment substances).

Disposal guidelines



Packaging and packaging aids can and should always be recycled. The product itself may not be disposed of as domestic refuse.

Service & Support

Service & Support Portal

On the main support page, you can find a wealth of useful information about the range of services we offer, documents, downloads and much more:
Industry Online Support (<https://support.industry.siemens.com>)

Technical support

You can access technical support through the following communication channels:

- Internet:
Web form for support request (<http://www.siemens.com/SupportRequest>)
- Smartphone:
Siemens Industry Online Support App
(<https://support.industry.siemens.com/cs/ww/en/sc/2067>)

Technical documentation on the Internet

Operating instructions and manuals for SITOP are available in the Internet:
Operating instructions/manuals (<https://www.siemens.com/sitop-manuals>)

SITOP power supply homepage

Current information about our power supplies is available in the Internet at the SITOP home page:
SITOP (<http://www.siemens.com/sitop>)

Texts for invitation to tender

You can find invitation to tender texts for SITOP power supplies here:
Link to the portal (<http://www.siemens.de/ausschreibungstexte>)

CAX data

You can find 2D-/3D data, devices circuit diagrams according to IEC and ANSI as well as EPLAN macros as download in the Internet:
Siemens image database (<http://www.siemens.com/sitop-cax>)

Request all CAX data via the CAX download manager:
CAX shopping cart (<http://www.siemens.com/cax>)

TIA Selection Tool

Simply and quickly select the optimum power supply, add-on modules and DC-UPS:
TIA Selection Tool cloud (<http://www.siemens.com/tst-powersupply>)

In addition, the 24 V load view in the TIA Selection Tool allows you to simply select the power supply for your particular project as the current demand of the automation products being supplied is automatically calculated.

Download the TIA Selection Tool (<http://www.siemens.de/tia-selection-tool-standalone>)

Online catalog and ordering system

The online catalog and the online ordering system are available through the Industry Mall homepage:

Industry Mall (<http://www.siemens.com/industrymall/de>)

Contact persons

If you have any questions regarding the use of our products, then contact the Siemens contact person in your regional Siemens sales office.

You can find these addresses as follows:

- Internet (<http://www.automation.siemens.com/partner>)
- Industry Mall (<http://www.siemens.com/industrymall/de>)